

Corporate and Brand Identity Design Competition

Product 2

- Design brief
 - Name: **VeeFem**
 - Product: **Sanitary Napkins** and **reusable pads**
 - Required Submissions (these designs are required to be eligible to participate):
 - Logo Design
 - Product Packaging Mockup and size for **sanitary pads**
 - Sticky cover on the backside of the pad.

Ref. Picture:

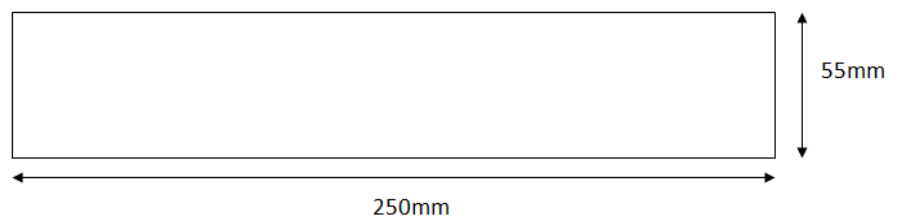

Size: 250mm-55mm

- The outer box containing 8 pads

Ref. Picture:

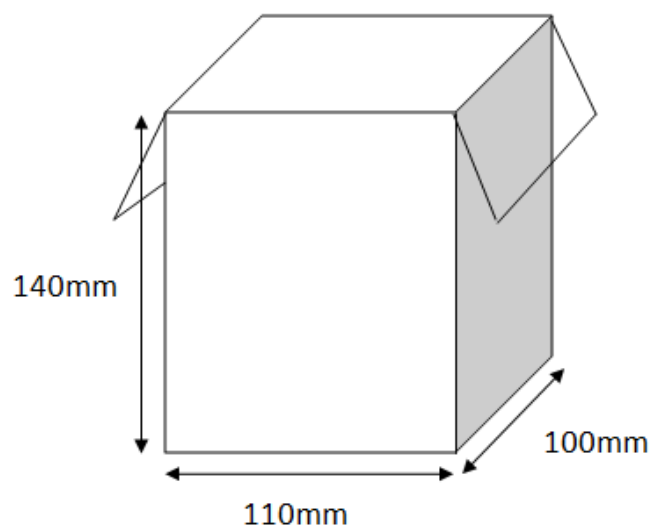

Size: 140mm-110mm-100mm

- Product Packaging Mockup and size for reusable pads
 - The outer box for a single reusable pad:

Ref. picture:

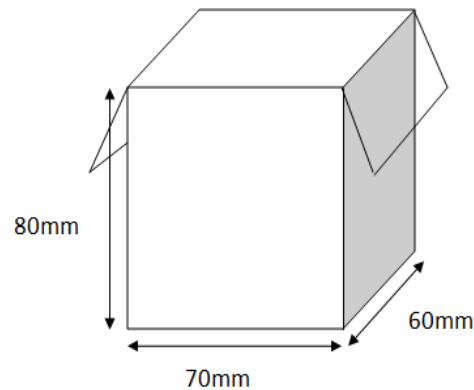

Size: 80mm-70mm-60mm

- Ad Campaign (3 Varieties): Design the graphics and text for a catchy ad campaign which can be pitched to young adults and teens in the rural areas.
- **Additional Submissions (these designs are not mandatory to submit, but could contribute to your evaluation):**
 - Business Card
 - Letterhead Design
 - Envelope Design
 - Social Media Banners
- **Client's Design Specifications:**
 - Designs should be simple and flexible (especially for the logo)
 - Designs should aim at achieving any of the following attributes:
 - Elegance
 - Necessity
 - Comfort
 - Freedom
 - Femininity
- **Colour Palette:** No restrictions
- **Customer Demographics:**
 - Teens, young adult women, women upto 40 years of age